

WPP-333-D SPECIFICATIONS

HANDSET TELEPHONE PANEL WITH AUTODIAL & SMART FEATURES IN A WEATHERPROOF HOUSING

Heavy duty weatherproof stainless steel phone in a cast aluminum black housing with TELEPHONE on door and pin latch for wall or pole mount. Designed to dial a preprogrammed number when the handset is lifted off-hook. Programmable from 1-25 digits, PBX, prefix, or access dialing capability, and incoming call block. Equipped with marine quality chrome mechanical hookswitch, ID window, 18" hearing aid compatible armored cord handset or optional (-CCH5) 5 foot industrial strength coiled cord handset, and tamper resistant security screws. WPP models available in black, (-R) red, (-Y) Yellow, or (-G) Gray with TELEPHONE or EMERGENCY on door.



SPECIFICATIONS

Panel Size:	7 1/6"W x 11 1/4"H
Weatherproof Housing:	9 1/2"W x 12 5/8"H x 8"D (Including Door)
Weight:	Approximately 17 lbs.
Mounting Instructions:	Weatherproof Housing 4 holes spaced 8" x 5 7/8" Also available pole mounting bracket
Environment:	Temperature: -30°C (-22°F) to 60°C (140°F) Humidity: 0%-90% non-condensating
Programming:	Via DTMF Keypad
Memory Retention:	Lithium Battery- Long life
Input Power:	Telephone Line Powered
Loop Current:	25mA min to 80mA max
Impedance:	600 ohms
Type Jack:	RJ11C
Ringer Equivalency:	0.4A dbm.
Hearing Aid Compatible:	Meets EIA standards
UL & FCC Registration:	Certified
ACCESSORIES:	301-064 Security Tool (required for installation)

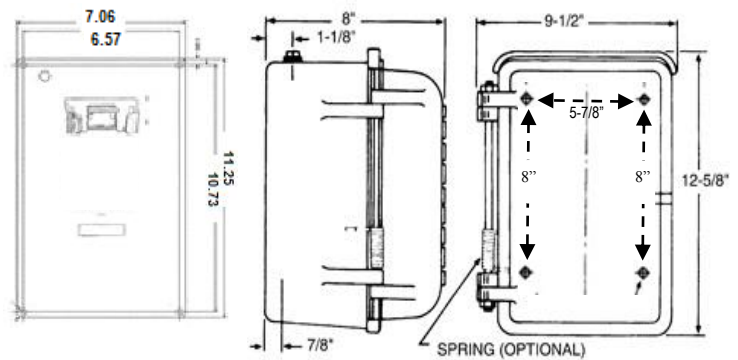

ADDITIONAL OPTIONS

IP - Voice over Internet Protocol Version available on all models (SIP)

-M	-IVC	-CCH*	-LB	Weatherproof Housing	-ST/-SB/-RST	-RIL	-SP	Pole Mount
Sealed Magnetic Hookswitch • Completely Sealed • No Moving Parts	Push Button Volume Control Background Noise reduction	Coiled cord available from 5', 10', & 15' (feet). Example: -CCH5 5' Long	Handset w/ internal steel lanyard (braided metal rope) and lanyard mounting bracket that is secured onto panel for added strength.	Standard Black & TELEPHONE on Door -B-EMER Black & EMERGENCY on Door -R Red & EMERGENCY on Door -R-TEL Red & TELEPHONE on Door -Y Yellow & EMERGENCY on Door -Y-TEL Yellow & Telephone on Door -G Grey & TELEPHONE on Door -G-EMER Grey & EMERGENCY on Door	Blue Strobe Light option: • Steady on • Flashing • For location visibility • Requires AC power	Ring Indicator Light located on the phone panel for visual ring indication.	Spring loaded door option	Pole Mounting bracket fits poles 2.5" - 6".



Providing Telecommunication Solutions Since 1930

Communication Equipment
& Engineering Company

519 SW Park Street

Okeechobee, FL

<http://www.ceeco.net>

Voice 863-357-0798

Email: sales@ceeco.net

Fax 863-357-0006