

WPP-531-FD TELEPHONE

Weatherproof, Vandal Resistant, Rugged Speakerphones Built to Last

The CEECO handsfree telephone is a sturdy, vandal resistant, stainless steel panel speakerphone. Instead of a hookswitch and handset, the telephone has a Press to start/Press to stop button for initiation and termination of phone calls. The Emergency Auto Dial button is also provided for one button dialing of a preprogrammed emergency number of up to 11 digits. The ADA feature incorporates a call progress indicator that illuminates red when the red Emergency Button is pushed, flashes red and green during ringing, and illuminates green when the call is answered. When the phone is used to make normal calls with the black Call Button, the LED simply illuminates red during "off-hook" periods. ADA versions are also equipped with an EMERGENCY Braille Plate.



WPP-531-F TELEPHONE

Designed for Rugged and Outdoor Environments

Weatherproof Cast Aluminum Housing with Stainless Steel Panel Telephone

ADA Feature with LED indicator and Braille Emergency Plate

Wall or Pole Mount

Speed Dial and Call Restriction Capability to include Call Allow and Block Tables

Line Powered

1 Year Warranty

ORDERING INFORMATION—Parts

705-110	Keypad
700-008-2	Keypad Cable
301-660-000	CEECO SPK Board
301-6020B	Momentary Panel Switch
301-660	Speaker
401-009	Ringer
301-009	Network
301-018	Modular Cord
301-054-UL	Modular Connector (RJ11C)
331-006	Security Screws
331-005	Weatherproof Enclosure with Door
SSP-511-FD	Replacement Telephone without enclosure

OPTIONS

-R	Red Housing EMERGENCY
-R-TEL	Red Housing TELEPHONE
-Y	Yellow Housing EMERGENCY
-Y-TEL	Yellow Housing TELEPHONE
-G	Gray Housing TELEPHONE
-ST	Strobe Light
-PB	Pushbutton Latch Housing
-BR	Braille Emergency Plate
-ADA	LED Indicator Light and Emergency Plate
-SS	Super Smart Features include: Voice Announcement (-VA), Auto Answer (-AA), and Remote Programming (-RP)
331-016	Spring Loaded Door
301-006	Pole Mounting Bracket



Providing Telecommunication Solutions Since 1930

Communication Equipment
& Engineering Company

<http://www.ceeco.net>

Email: sales@ceeco.net

519 SW Park Street
Okeechobee, FL 34972

Voice 863-357-0798

Fax 863-357-0006

SPECIFICATIONS

(required for installation)

SPECIFICATIONS

INPUT POWER:	C.O. Line Powered
LOOP CURRENT:	30ma min to 80ma max
IMPEDANCE:	600 ohms
OUTPUT:	-4.0 to -6.0dbm
SIGNALING	DTMF, 70ms tone, 50 ms spacing
ENVIRONMENTAL:	Temperature 0°C to 50°C Humidity 20%-90% non-condensating
PROGRAMMING	Via DTMF keypad
RINGER EQUIVALENCY:	0.7A
FACEPLATE:	Brushed 16 ga. Stainless Steel Cast Aluminum
ENCLOSURE:	
DIMENSIONS:	
HOUSING:	12 5/8" H x 9 1/2" W x 8" D (including door)
PANEL:	11 1/4" H x 7 1/16" W
MOUNTING:	4 Holes spaced 8" x 5 7/8"
WEIGHT:	16 lbs.
MEMEORY RETENTION:	Non-volatile
FCC REGISTRATION:	BW88T7-13716-TE-T
UL LISTED NO.:	6OF5
TYPE JACK:	RJ11C
ACCESSORIES:	
301-064	Security Tool

WARRANTY POLICY

GENERAL

CEEEO guarantees its products to be free from defects in material and workmanship for a period of 365 days from the date of original purchase. CEEEO's obligation under this warranty is limited to repair or replacement of any part found to be defective by CEEEO.

UNDER NO CIRCUMSTANCES shall CEEEO be liable for loss, damage, cost of repair or consequential damages of any kind, which have been caused by neglect, abuse or improper operation of equipment.

CEEEO will repair or replace any unit during this period if found to be defective for reasons other than abuse and improper use or improper installation. It is the buyer's responsibility to return the defective unit to the factory. CEEEO will then repair or replace any defective parts and return them to the buyer free of charge. CEEEO will continue to offer repair service for the life of the product.

REPAIR POLICY

WARRANTY REPAIR

Any device returned requiring warranty service, repair or credit must be accompanied with a "Return Material Authorization" (RMA) Form. It must include: RMA Number, return shipping instructions, original purchase order number, serial number and special marking instructions. A tag with the trouble observed must be attached to the defective unit. This information must be inside the shipping container.

NON-WARRANTY REPAIR

CEEEO will repair equipment out of warranty for a set charge plus parts. The customer must pay the shipping costs both directions.

CEEEO has been providing telecom solutions since 1930. Our vandal resistant technology focuses on providing public communication solutions while reducing replacement and repair costs, lowering the customer's total cost of ownership. CEEEO also offers custom design and branding to your specifications.

Our commitment to providing expert service and support extends beyond the warranty of our product. We offer service for the life of the product! CEEEO is devoted to giving you the quality and service you deserve.

MECHANICAL DIMENSIONS

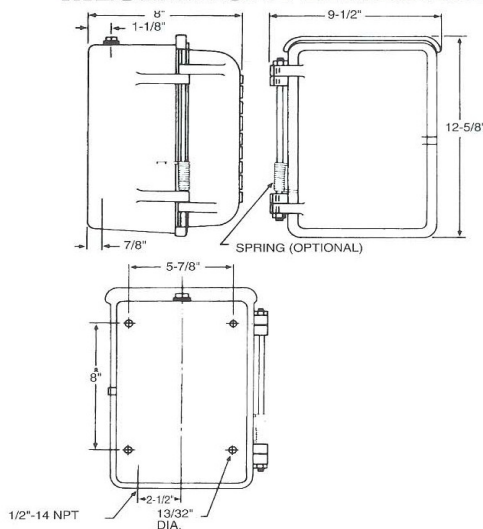

Providing Telecommunication Solutions Since 1930

Communication Equipment
& Engineering Company

<http://www.ceeco.net>

Email: sales@ceeco.net

519 SW Park Street
Okeechobee, FL 34972

Voice 863-357-0798

Fax 863-357-0006